

TECHNISCHE FOCUS OP DE WATERTANKS

Technische gids voor de juiste aankoop



JOSKIN®

WATERTANKS

EENVOUDIG EN EFFICIËNT

Standaard  of optionele uitrusting 

 2" 1/2 kogelventiel achteraan voor het snel en nauwkeurig doseren.



 2" 1/2 doseerbare verdeler in plaats van 2" 1/2 kogelventiel.



 Drinkbak voor 1 dier uitgerust met een mechanisme met een toevoerklap.



 70 l drinkbak met constant niveau met 1" afsluiter (voor het sluiten bij het transport), in achter- of zijpositie.



 1/4-slag kraan (2" 1/2) om zachtjes te verspreiden.

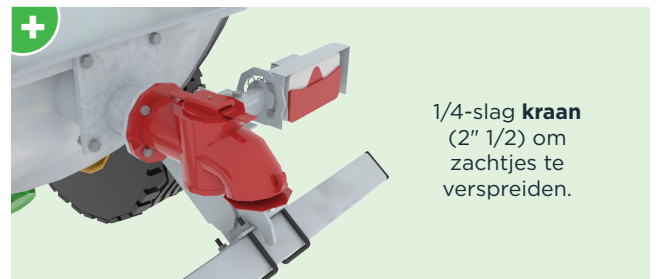

 Instelbare Ø 70 mm handbediende steunpoot (op mobiele watertank).



 Ø 450 mm deksel met snelopening en afdichting.



 Ruime keuze aan trekogen

- (A) Gelast Ø 50 mm vlak trekoo (standaard)
- (B) Scharmüller Ø 40 mm vlak trekoo (optie)
- (C) JOSKIN Ø 80 mm kogelscharnieroog (optie)
- (D) JOSKIN Ø 50 mm draaibaar trekoo (optie)



 (A) Centrifugaalpomp voor het vullen: 1 000 l/min debiet, 540 omw/min cardanaandrijving.

(B) 6 m, Ø 60 mm zuigslang met terugslagklep en systeem om de bodem van de put niet aan te raken.



 Secundair circuit voor centrifugaalpomp voor het vullen, afvoeren, overbrengen (zonder stroming door de tank) en mengen in een gesloten circuit (geleverd met 2de haspel).

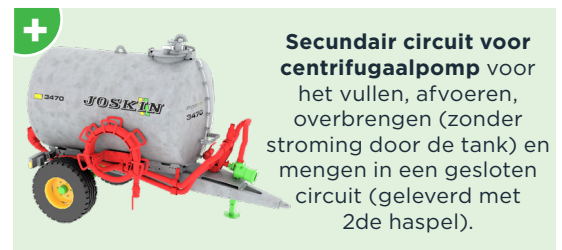

 Zijlichten



 Ruimte voor kentekenplaat met verlichting voor een betere zichtbaarheid 's nachts.



 Beschermd niveaumeter, buiten bereik van de dieren.



 Elektrische afvoerpomp (12 V) - m.i.v. pistool, teller en 4 m van 1" slang.



 Scharnierende achterlichten die handmatig kunnen worden ingeklapt om schade door het vee te voorkomen.

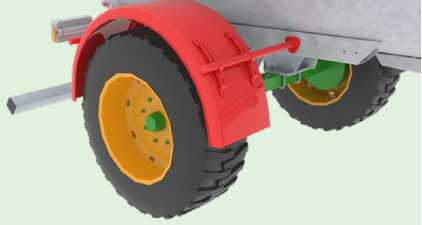

✓  **Geleverd als een ongemonteerde kit** om de kosten en afmetingen bij het transport te beperken.

✓ **Spatborden** om spatten te beperken. 

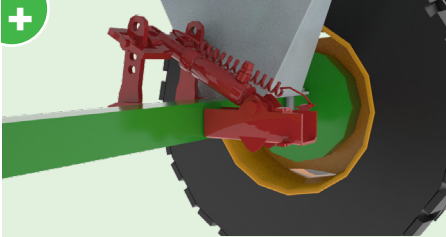
✓ **Hydraulische remmen** 

✓ **Luchtremmen:** Niet beschikbaar op mobiele tanks van 1 725 l (standaard op Aquatrans XL). 

✓ **Hydraulische en luchtremmen:** Niet beschikbaar op mobiele tanks van 1 725 l. 

✓ **Grote keuze aan banden**

- Ø 1 076 tot 1 250 mm
- Breedte: 390 tot 568 mm
- Banden van de grootste merken

   

400R22.5 Standaard 550/60-22,5 560/45R22.5 560/60R22.5

En nog veel meer!

✓ **Oplooppemmen** in overeenstemming met de EU normen (3470, 4300, 5100, 6000S en 7000S modellen) voor 80-90 cm hoge aanspanning.  

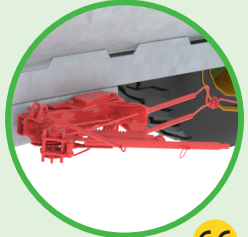
OPGELET: Ø 40 mm trekroeg. 

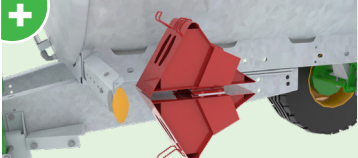
✓ **Wielblokken** 

✓ **Vaste dissel** 

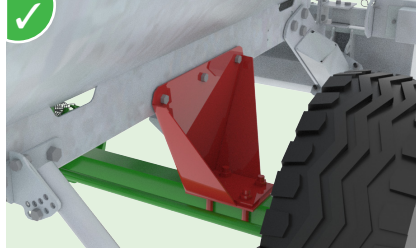
✓ **Brede assteun** 

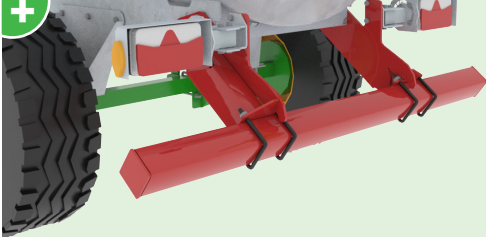
✓ **Achterbumper** 

✓ **Hoekijzer** over de hele lengte van de tank (behalve Aquatrans XL). 

✓ **Zijbumpers** 

✓ In de tank geïntegreerde **golfbrekers**, in overeenstemming met de EU normen, om de golvende bewegingen van het water bij het transport te voorkomen (vanaf 3 470 l). 

✓ **Trappen** (om bij de Ø 450 mm deur met de watervulpijp te komen). 

AQUATRANS GAMMA

VAN 1 725 TOT 10 000 L

AQUATRANS

- ✓ Inhoud van 1 725 tot 5 100 l
- ✓ Tank van 2,39 tot 4,35 m lang
- ✓ Diameter van 1 tot 1,4 m
- ✓ Tank uit gegalvaniseerd staal met hoge elasticiteitsgrens (dikte: 4 mm)
- ✓ Laag leeggewicht

Statische tanks

(identieke tanks)

Mobiele tanks

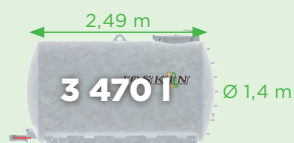
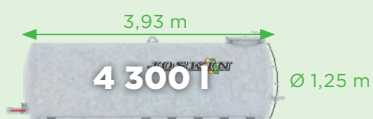
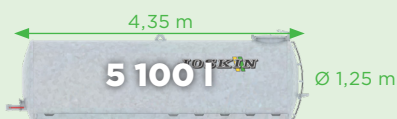

AQUATRANS XL

- ✓ Inhoud van 6 000 tot 10 000 l
- ✓ Tank van 4,12 tot 4,88 m lang
- ✓ Diameter van 1,4 tot 1,7 m
- ✓ Tank uit gegalvaniseerd staal met hoge elasticiteitsgrens (dikte: 5 mm)
- ✓ Zelfdragende versterkte structuur

Mobiele XL tanks



AQUACUBE

- ✓ Inhoud: 2 100 l
- ✓ Afmetingen: l 1 715 x b 2 400 x h 640 mm
- ✓ 3-puntskoppeling aan de trekker



JOSKIN



www.joskin.com • Rue de Wergifosse, 39 - 4630 Soumagne (België)

E-mail: info@joskin.com • Tel.: +32 (0)4 377 35 45