

TECHNICAL FOCUS ON DELTA-CAP/SPACE & TETRA-CAP/SPACE

Technical Guide for Dropside Tipping Trailers



JOSKIN®

DELTA-CAP/SPACE & TETRA-CAP/SPACE

MODULARITY AND EFFICIENCY

Standard  or optional equipment 

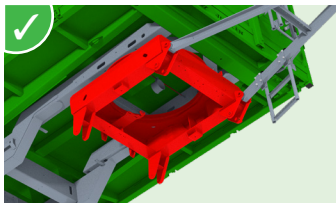

Monocoque frame with Ø 100 cm turntable connecting the drawbar to the axle leaf bundle on Tetra-CAP/SPACE.



Semi-mounted Delta-CAP/SPACE for work in difficult conditions.



Tetra-SPACE 24 t with weight transfer to tractor (max. 4,000 kg).

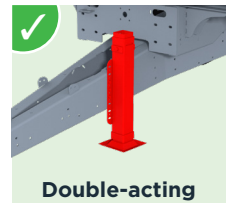

Double-acting hydraulic parking stand on Delta-CAP (optional on model 4525).

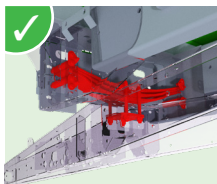

Multi-position spring leaf suspension between the drawbar and chassis on Delta-CAP.

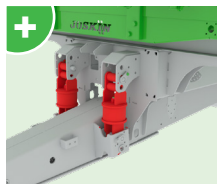

Drawbar with silentblock suspension on Delta-SPACE.

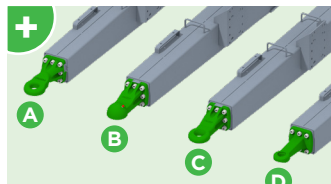

Wide choice of bolted eyelets on Delta-CAP
 (A) Ø 50 mm swivel eye
 (B) Ø 80 mm knee-joint eyelet
 (C) Ø 50 mm fixed eyelet (standard)
 (D) Ø 40 mm fixed eyelet



Wide choice of bolted eyelets on Delta-SPACE
 (A) Ø 50 mm swivel eye
 (B) Ø 80 mm knee-joint eyelet (standard)
 (C) Ø 80 mm Scharmüller



Double-acting central hydraulic skid with direct connection to the tractor on Delta-SPACE.

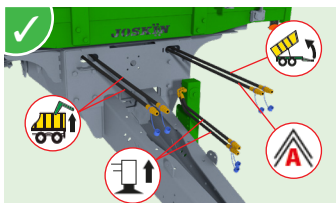

Numbered hydraulic hoses for an easy management of the spare parts + stickers indicating the function.

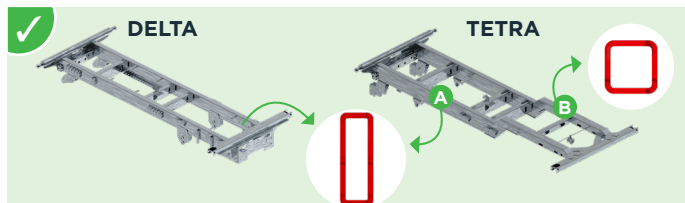

Galvanised tubular chassis sections

- Delta-CAP/SPACE: 250x100 or 300x100 mm
- Tetra-CAP/SPACE: 250x100 or 300x100 mm (section A) and 150x150 mm (section B)

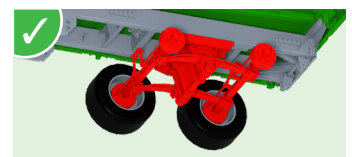

Roll-Over bogie suspension on Delta-CAP (tandem) for enhanced traction on difficult terrain.



Tridem spring leaf suspension on Delta-SPACE for a real agricultural and road trailer.

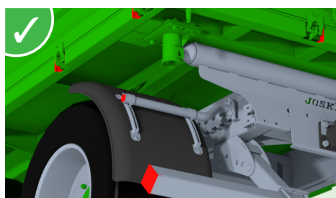

Plastic caps on the openings of the galvanised elements to prevent material build-up.

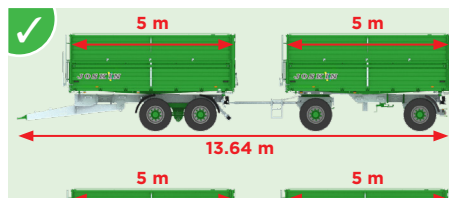

Road length with 2 trailers

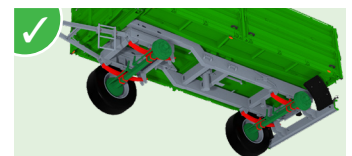

Parabolic leaf suspension on Tetra-CAP/SPACE for high flexibility and ease of use.

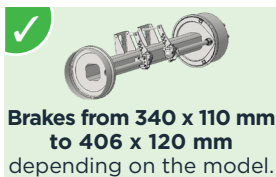

Brakes from 340 x 110 mm to 406 x 120 mm depending on the model.



Thermoplastic mudguards on all front and rear wheels on Tetra-SPACE and Delta-CAP/SPACE (optional on Tetra-CAP).



Rear thermoplastic mudguards on Tetra-CAP.



Winch for spare wheel (Tetra-CAP/SPACE).



Large choice of tyres
 • Ø 850 to 1,250 mm
 • Width: 356 to 568 mm

385/65R22.5 445/65R22.5 560/60R22.5
 And many more!



Flexible plastic caps with arrows to indicate the correct stud tightening.

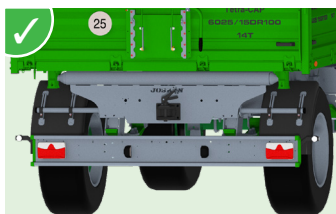

LED lights

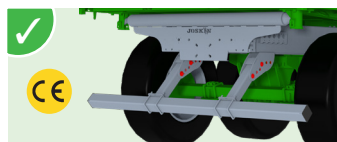

Multi-position height adjustment for the rear bumper



Document tube with individualised spare parts book.

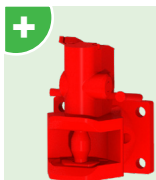

Automatic rear hitch instead of swivel rear hitch.

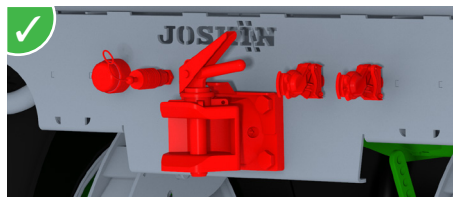

Complete connections for the lighting, braking and tipping system of a second trailer with swivel rear hitch.

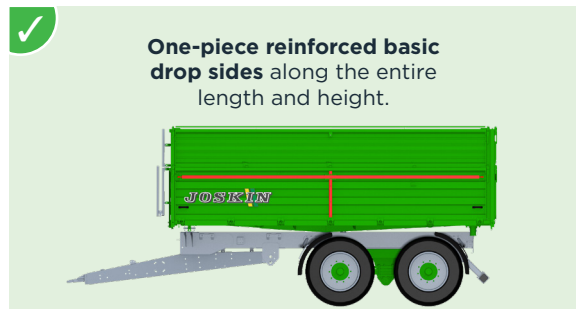

One-piece reinforced basic drop sides along the entire length and height.

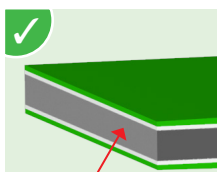

Floor in QST420MC special steel on all models (thickness: 4 mm).



3-way tipping system (rear, left and right). (A) Tipping cylinder on oscillating frame and side tipping angle automatically limited by a check valve.



Tubular drop sides for a greater resistance to pressure.

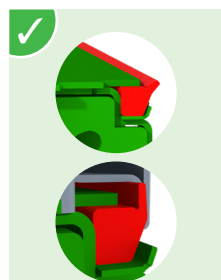

Rubber seals all around the body for a perfect tightness.



Locking of the drop sides with numerous hooks that increase the compression between the drop side and the body, ensuring a perfect tightness.



Front return springs for easy handling of the drop sides (only on models 4525 and 5025).

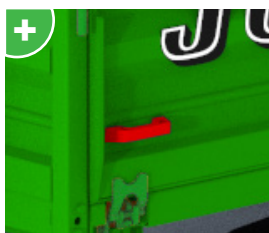

2 handling handles on each basic drop side.

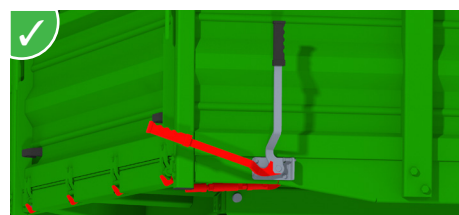

Adjustable locking system with a very large number of hooks on the side and rear drop sides to ensure a correct pressure on the seals.



Double hydraulic rear door lock with seal and built-in mechanical rods for a good protection.

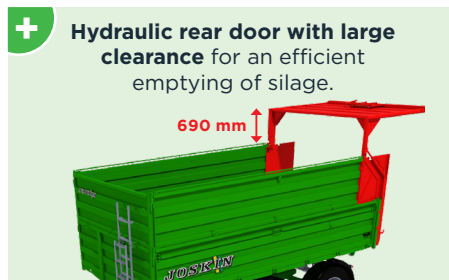

Hydraulic rear door with large clearance for an efficient emptying of silage.

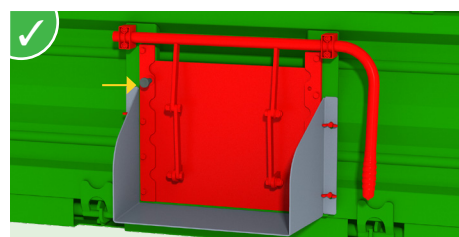

Large grain chute (opening: 390x300 mm) with automatic locking.

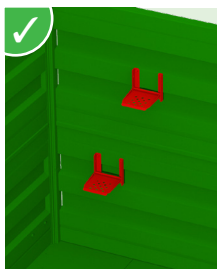

Galvanised steps inside the body



Ladder on the front wall to see inside the body.



Manual roll-up cover + platform for optimal safety

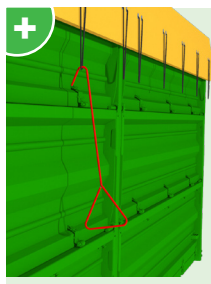

Hook for easy cover attachment, even with higher bodies.

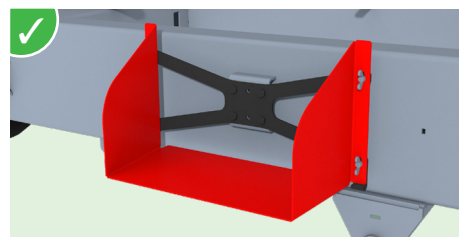

Spout for grain chute (440x240 mm) with storage under the body.

WIDE RANGE OF DROPSIDE TIPPING TRAILERS

3-way tipping system

DELTA-CAP & DELTA-SPACE

TETRA-CAP & TETRA-SPACE

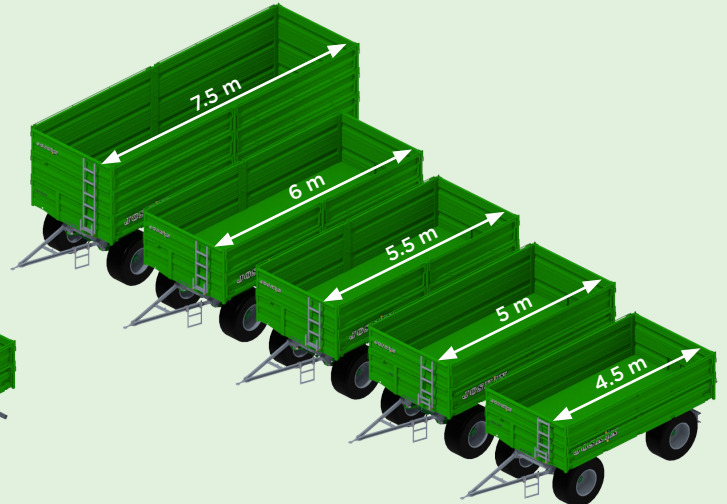
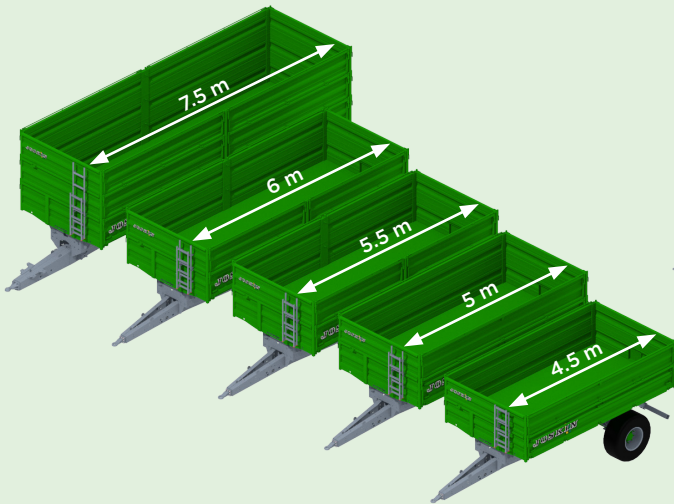

LARGE CHOICE OF OPTIONS

- Platform
- Manual roll-up cover
- Winch for spare wheel
- Spout for grain chute
- Hydraulic rear door with large clearance
- End outline marker lamps
- Mudguards
- Return springs on drop sides (models 4525 and 5025)
- Wide choice of wheels and bolted eyelets
- Automatic rear hitch
- Electrical and air connections for a 2nd trailer
- ...

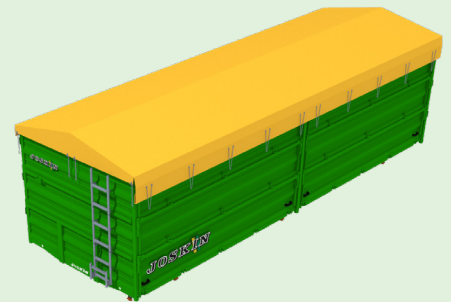

3 BASIC DROP SIDE HEIGHTS → 5 POSSIBLE COMBINATIONS*!

* Number of possible combinations depending on the model.

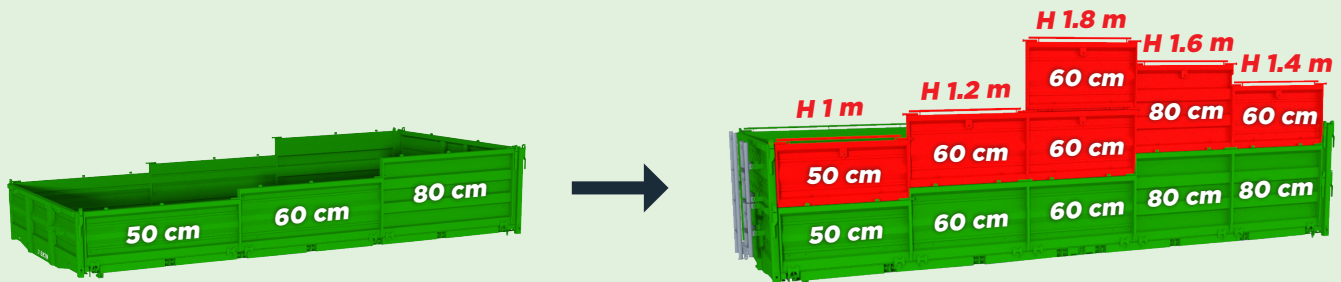

A dropside tipping trailer for the future of your business, with all the details you need!

JOSKIN



www.joskin.com • Rue de Wergifosse, 39 - 4630 Soumagne (Belgium)

E-mail: info@joskin.com • Tel.: +32 (0)4 377 35 45