

TECHNICAL FOCUS ON TRANS-EX

Technical guide for making the right purchase



JOSKIN®

TRANS-EX

COMPACT, SIMPLE, STURDY AND VERSATILE TIPPING TRAILER

Standard ✓ or optional + equipment

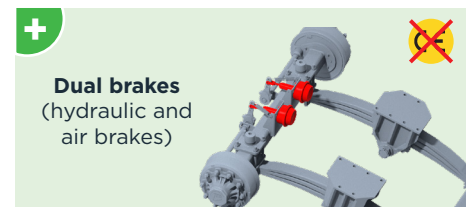
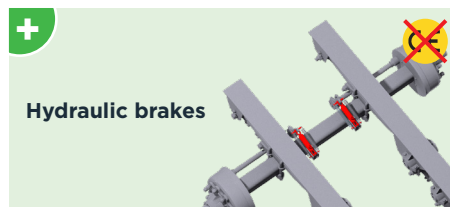
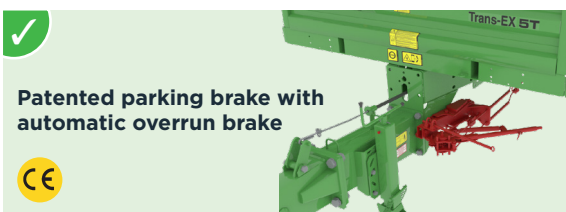
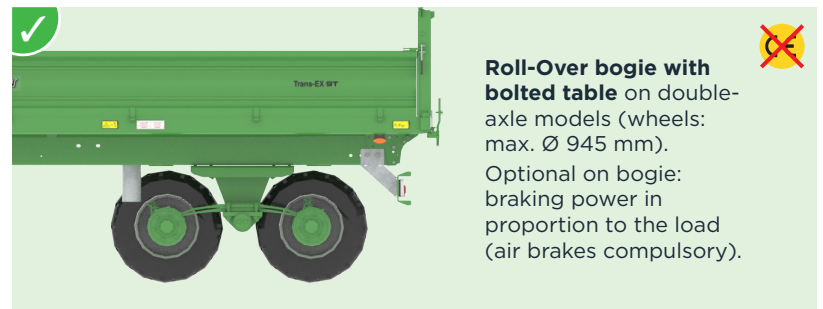
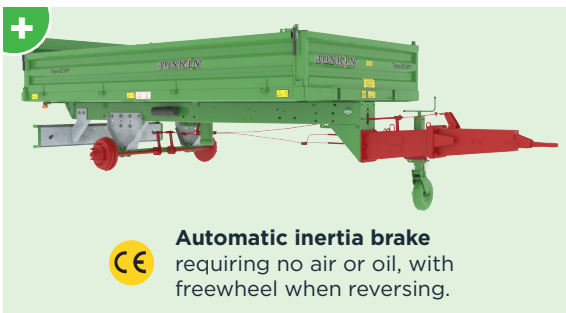
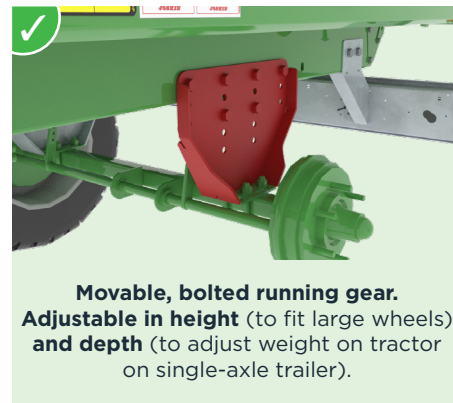
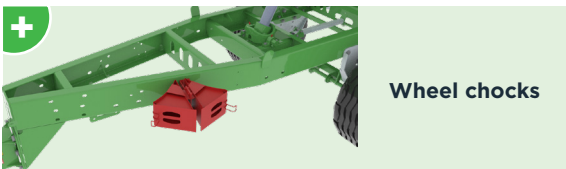
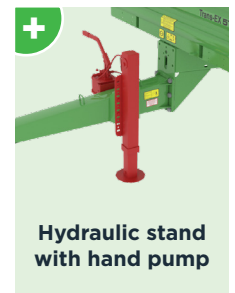
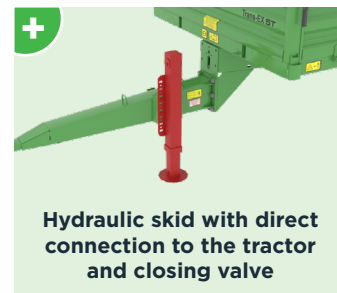
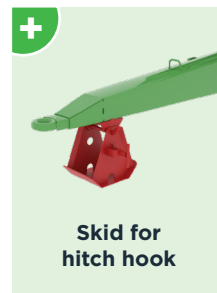
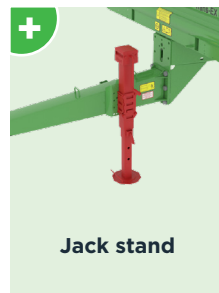
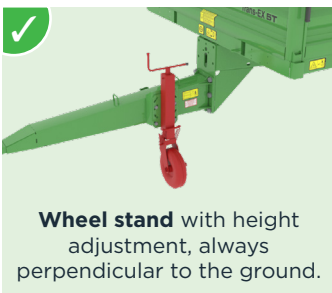
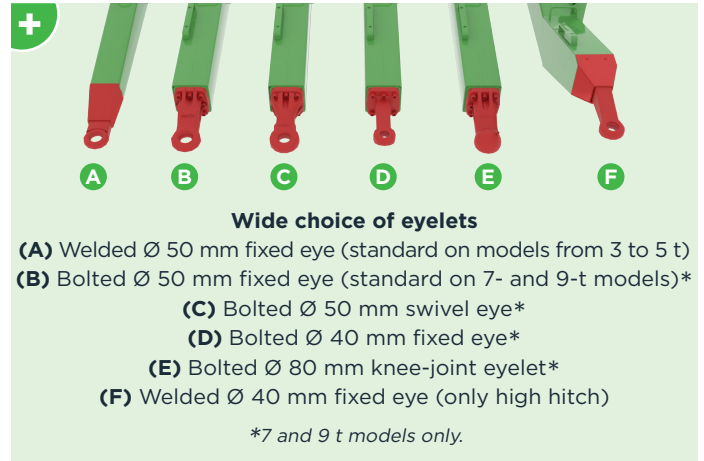
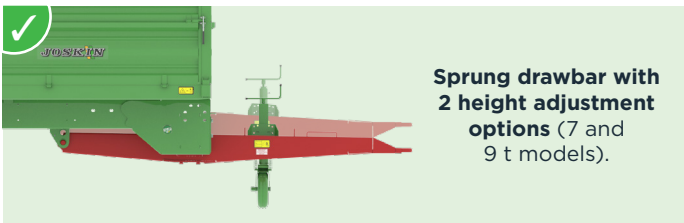
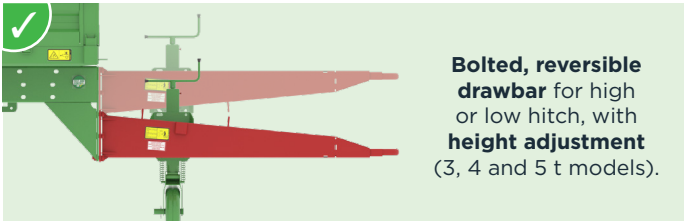

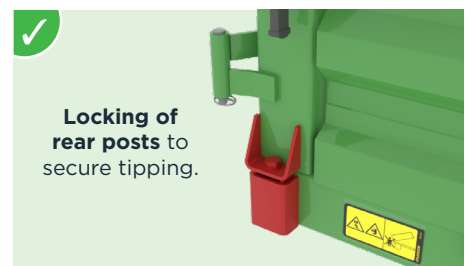
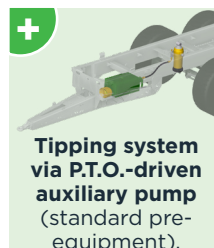
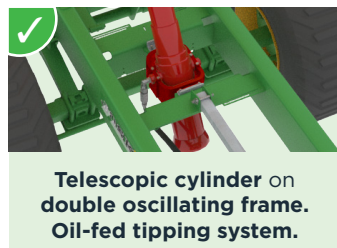
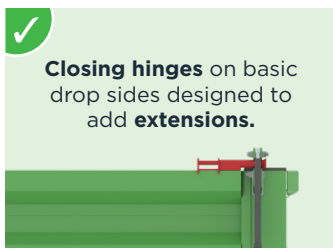
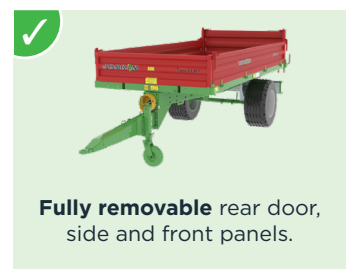
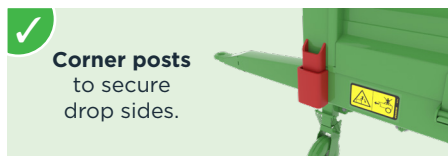
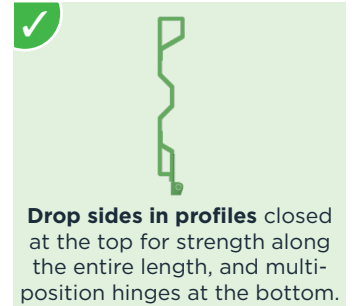
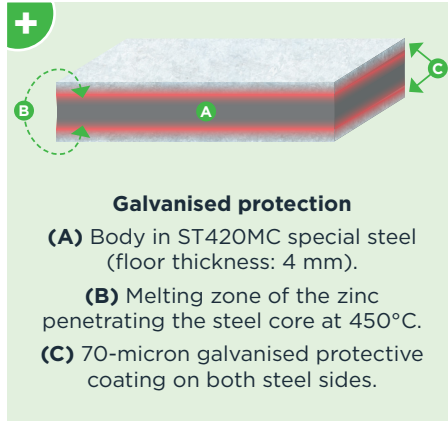
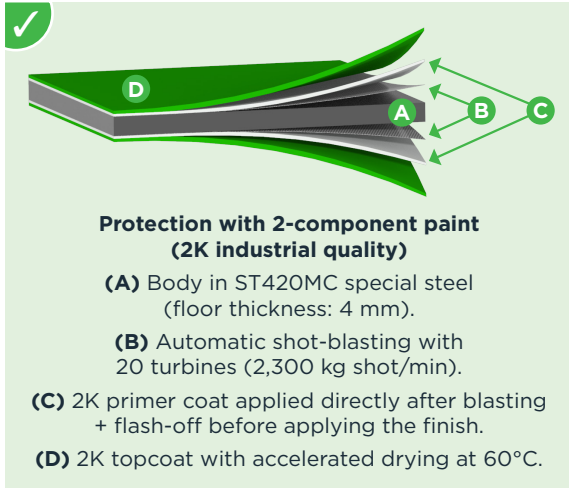
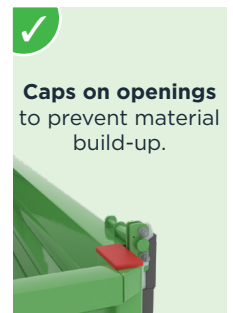
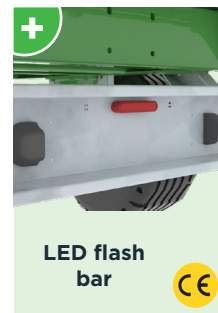
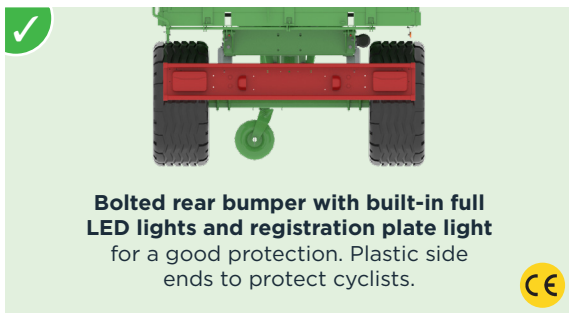

TRANS-EX

8 MODELS

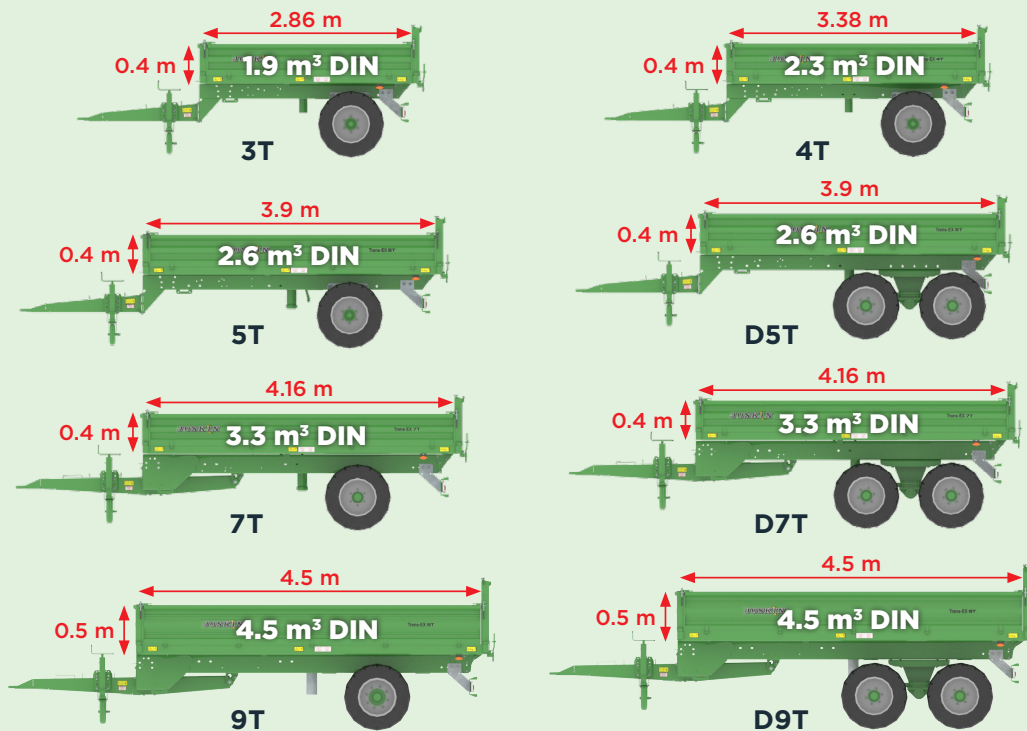

VARIOUS EXTENSIONS AVAILABLE

200 or 400 mm extensions (3, 4, 5 and 7 t models).

500 mm extensions (9 t models).



Max. height (drop sides + extensions): 1.2 m. Rear door height adapted to the height with extensions.

Measurements in cm.

Example of load with Trans-EX 5T

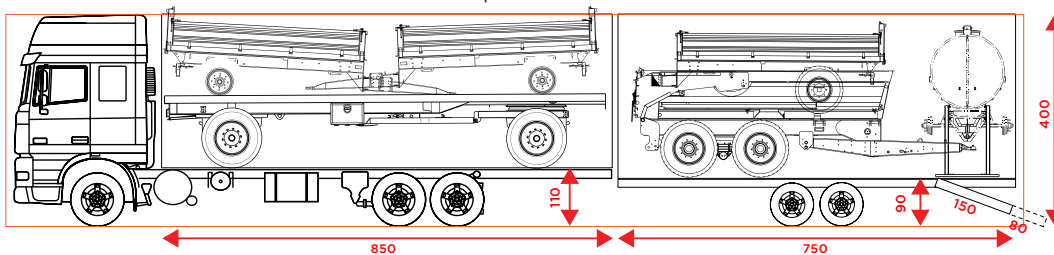

Special conditions for Trans-EX 5T delivered by lorry:

- as lost volume,
- in/on machines to be delivered.

See Focus folder about logistics.

JOSKIN



www.joskin.com • Rue de Wergifosse, 39 - 4630 Soumagne (Belgium)

E-mail: info@joskin.com • Tel.: +32 (0)4 377 35 45